

Sect. B-B

REFERANS			MOTOR TARAFI							
KW.	HP	E.MOTOR	KOD	A	B	D	D2	CH	T	Z
18,5 / 22	25 / 30	180	DK4803	47 & 67	14	68				42
			DK481903				19	6	21	
			DK482403				24	8	28	
			DK482803				28	8	32	
			DK483203				32	8	36	
			DK483803				38	10	43	
			DK484203				42	12	47	
DK484803	48	14	53							

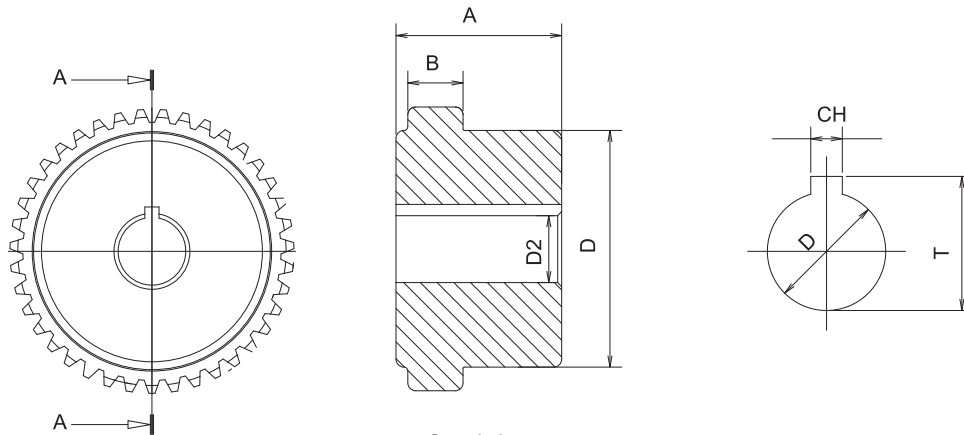

Sect. A-A

POMPA TARAFI														
KOD	A	B	B1	B2	D	D1	D 2	E	CH	T	H	K	Z	
DK481P03	47	14	20	9	68	35	16,66	25	4	-	2	1/8	42	
DK482503			-	-		-	25	-	6	28	3	-		
DK482PD03			-	-		-	22,15	-	6,35	25,15	3	-		
DK482PK03			-	-		-	22,15	20	4	-	2	-		1/8
DK483PK03			-	-		-	22,2	-	4	-	2	-		-
DK483PD03			-	-		-	32	-	8	36	4	-		-
DK48-G2B-03			-	-		-	12,5	-	3	-	1,5	-		1/5
DK48-1M03			-	-		-	13,9	-	3	-	1,5	-		-
DK48-G2-1403			-	-		-	14,3	-	4	-	2	-		-
DK48-2-03			-	-		-	17,2	-	4	-	2	-		1/8
DK48-2-03T			-	-		-	17,2	-	3,2	-	1,6	-		-
DK48-G3-03			-	-		-	18,36	-	4	-	2	-		-
DK48-G3B-03			-	-		-	19,3	-	5	-	2,5	-		1/5
DK48-SAE-A-03			-	-		-	19,05	-	5	21,55	2,5	-		-
DK48-G3,5-03			-	-		-	21,08	-	5	-	2,5	-		1/8
DK48-ZG-03			-	-		-	25,2	-	5	-	2,5	-		1/5
DK48-35-03T			-	-		-	25,6	-	4,76	-	2,4	-		-
DK48-35-03			-	-		-	25,6	-	5	-	2,5	-		1/8
DK48-4-03T			-	-		-	33,3	-	6,35	-	3,2	-		-
DK48-4-03			-	-		-	33,3	-	7	-	3,5	-		-