

Sect. B-B

REFERANS			MOTOR TARAFI							
KW.	HP	E.MOTOR	KOD	A	B	D	D2	CH	T	Z
5,5 / 7,5	7,5 / 10	132	DK3803	42 & 62	14	58				37
			DK381903				19	6	22	
			DK382403				24	8	28	
			DK382803				28	8	32	
			DK383203				32	8	36	
			DK383803				38	10	43	

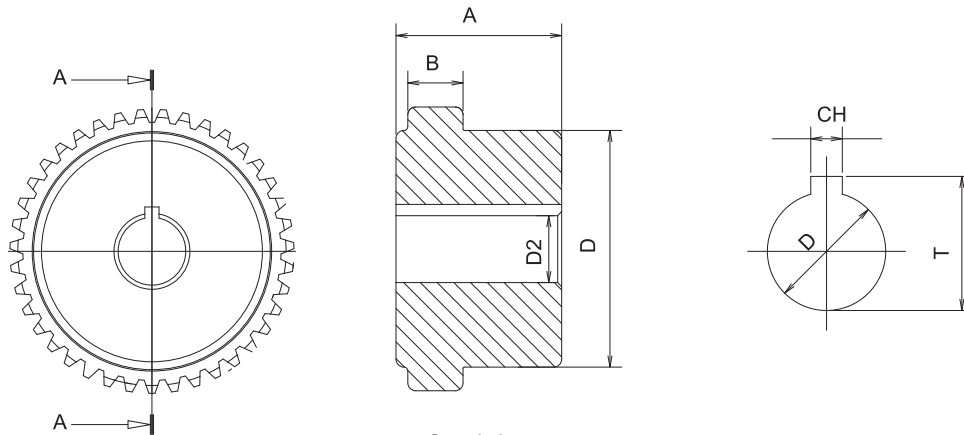

Sect. A-A

POMPA TARAFI														
KOD	A	B	B1	B2	D	D1	D 2	E	CH	T	H	K	Z	
DK381P03	42	14	15	10	58	35	16,66	20	4	-	2	1/8	37	
DK383PK03			-	-		-	22,2	-	4	-	1,5			
DK383PD03			-	-		-	-	29,21	-	8	33,21	4		-
DK382PD03			-	-		-	-	22,15	-	6,35	25,35	3,2		-
DK384P03			-	-		-	-	12,5	-	4	-	2		1/5
DK382PK03			-	-		-	-	22,15	15	4	-	2		1/8
DK38-G2B-03			-	-		-	-	12,5	-	3	-	1,5		1/5
DK38-1M03			-	-		-	-	13,9	-	3	-	1,5		1/8
DK38-G2-1403			-	-		-	-	14,3	-	4	-	2		
DK38-2-03			-	-		-	-	17,2	-	4	-	2		1/8
DK38-2-03T			-	-		-	-	17,2	-	3,2	-	1,6		
DK38-G3-03			-	-		-	-	18,36	-	4	-	2		1/5
DK38-G3B-03			-	-		-	-	19,3	-	5	-	2,5		
DK38-SAE-A-03			-	-		-	-	19,05	-	5	21,55	2,5		-
DK38-G3,5-03			-	-		-	-	21,08	-	5	-	2,5		1/8
DK38-ZG-03			-	-		-	-	25,2	-	5	-	2,5		1/5
DK38-35-03T			-	-		-	-	25,6	-	4,76	-	2,4		1/8
DK38-35-03			-	-		-	-	25,6	-	5	-	2,5		
DK38-4-03T			-	-		-	-	33,3	-	6,35	-	3,2		
DK38-4-03			-	-		-	-	33,3	-	7	-	3,5		